

Coupled Inductor Based High Step-Up DC-DC Converter for Multi Input PV System

G. Shiny Vikram

Asst.Proff in Department of EEE, Swarnandhra Institute Of Engineering & Technology (SIET)-Seetharampuram, Andhra Pradesh

Abstract

With the shortage of the energy and ever increasing of the oil price, research on the renewable and green energy sources, especially the solar arrays and the fuel cells, becomes more and more important. How to achieve high step-up and high efficiency DC/DC converters is the major consideration in the renewable power applications due to the low voltage of PV arrays and fuel cells. In this paper a coupled inductor dc-dc converter for photovoltaic system is proposed. The circuit configuration of the proposed converter is very simple. Thus, the proposed converter has higher step-up and step-down voltage gains than the conventional bidirectional dc-dc boost/buck converter. Under same electric specifications for the proposed converter and the conventional bidirectional boost/buck converter, the average value of the switch current in the proposed converter is less than the conventional bidirectional boost/buck converter. The operating principles have been applied to multi input photovoltaic system and outputs have been observed.

Index terms: boost, pv array, coupled inductor, stepup/step down.

I. Introduction

The massy usage of the fossil fuels, such as the oil, the coal and the gas, result in serious greenhouse effect and pollute the atmosphere, which has great effect on the world. Meanwhile, there is a big contradiction between the fossil Fuels supply and the global energy demand, which leads to a high oil price in the international market recently. The energy shortage and the atmosphere pollution have been the major limitations for the human development. How to find renewable energy is becoming more and more exigent.

As the output voltage of the solar panel is very low and there should be a clear transformation for such low voltage to high voltage. Hence such work could be done by boost converter. The dc-dc boost converters are used to convert the unregulated dc input to a controlled dc output at a desired voltage level. They generally perform by applying a dc voltage across an inductor or transformer a period of time (usually in the 20 kHz to 5 MHz range) which causes current to flow through it and store energy magnetically, then switching this voltage off and causing the stored energy to be transferred to the voltage output in a controlled manner. The output voltage is regulated by adjusting the ratio of on/off time.

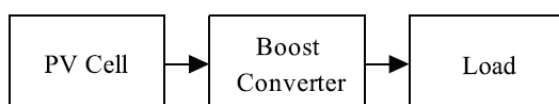

Fig 1: Block diagram

II. Photovoltaic Array

PV array's output current-voltage curve reflects PV array's dependence on environmental conditions such as ambient temperature and illumination level. Typically, the illumination level ranges from 0 to 1100Wb/m² and the temperature range is between 233 and 353 K. Normally, we select 1100 and 298 as the reference values for illumination level and temperature respectively. The relationship between PV array's output characteristics and environmental conditions could be illustrated from general simulation results of PV array. PV array's output power is increased as illumination level increases, while PV array's output power is improved with the decrease of the ambient temperature. The equivalent circuit of a typical pv-cell is given below.

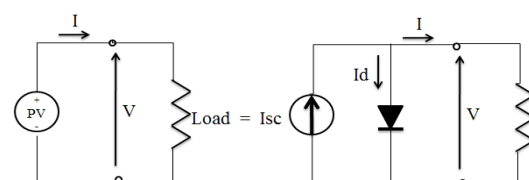

Fig 2: Simple equivalent circuit of a PV-cell

Figure reflects a simple equivalent circuit of a photovoltaic cell. The current source which is driven by sunlight is connected with a real diode in parallel. In this case, PV cell presents a p-n junction characteristic of the real diode. The forward current could flow through the diode from p-side to n-side with little loss. However, if the current flows in

reverse direction, only little reverse saturation current could get through. All the equations for modeling the PV array are analyzed based on this equivalent circuit

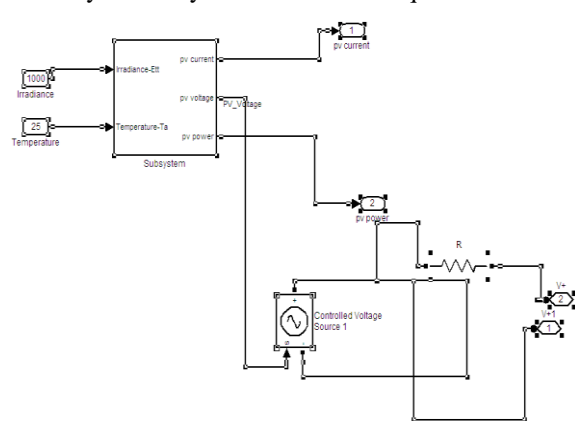

Fig 2.1 Mat lab model of single pv-cell

III. Coupled inductor Boost converter

Bidirectional dc–dc converters are used to transfer the power between two dc sources in either direction. These converters are widely used in applications, such as hybrid electric vehicle energy systems, uninterrupted power supplies, fuel-cell hybrid power systems photovoltaic hybrid power systems and battery chargers .Many bidirectional dc–dc converters have been researched. The bidirectional dc–dc fly back converters are more attractive due to simple structure and easy control However; these converters suffer from high voltage stresses on the power devices due to the leakage inductor energy of the transformer. In order to recycle the leakage inductor energy and to minimize the voltage stress on the power devices, some literatures present the energy regeneration techniques to clamp the voltage stress on the power devices and to recycle the leakage inductor energy .Some literatures research the isolated bidirectional dc–dc converters, which include the half-bridge and full-bridge types .These converters can provide high step-up and step-down voltage gain by adjusting the turns ratio of the transformer. The multilevel type is a magnetic less converter, but 12 switches are used in this converter.

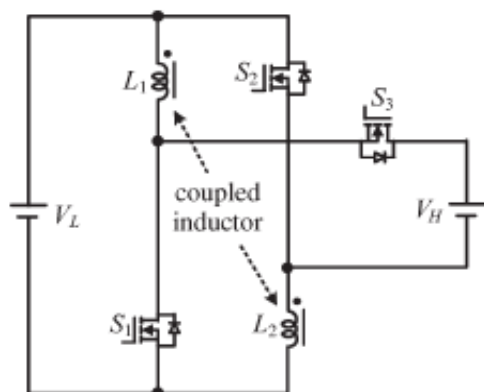

Fig 3: Proposed boost converter

A modified dc–dc boost converter is presented the voltage gain of this converter is higher than the conventional dc–dc boost converter. Based on this converter, a novel bidirectional dc–dc converter is proposed, as shown in Fig. 2. The proposed converter employs a coupled inductor with same winding turns in the primary and secondary sides. Comparing to the proposed converter and the conventional bidirectional boost/buck converter, the proposed converter has the following advantages: 1) Higher step-up and step-down voltage gains and 2) lower average value of the switch current under same electric specifications. The following sections will describe the operating principles and steady-state analysis for the step-up and step-down modes. In order to analyze the steady-state characteristics of the proposed converter, some conditions are assumed: The ON-state resistance $R_{DS(ON)}$ of the switches and the equivalent series resistances of the coupled inductor and capacitors are ignored; the capacitor is sufficiently large; and the voltages across the capacitor can be treated as constant.

3.1 .Step-Up Mode

The proposed converter can be used for both step up and step down modes with suitable switching of the devices. The proposed converter in step-up mode is shown in Fig. 3. Since the primary and secondary winding turns of the coupled inductor is same, the inductance of the coupled inductor in the primary and secondary sides are expressed as

$$L1 = L2 = L. \quad (1)$$

Thus, the mutual inductance M of the coupled inductor is given by

$$M = k\sqrt{L1 L2} = KL \quad (2)$$

Where k is the coupling coefficient of the coupled inductor. The voltages across the primary and secondary windings of the coupled inductor are as follows:

$$v_{L1} = L1 \frac{di_{L1}}{dt} + M \frac{di_{L2}}{dt} = L \frac{di_{L1}}{dt} + kL \frac{di_{L2}}{dt} \quad (3)$$

$$v_{L2} = M \frac{di_{L1}}{dt} + L2 \frac{di_{L2}}{dt} = kL \frac{di_{L1}}{dt} + L \frac{di_{L2}}{dt}. \quad (4)$$

Since the proposed converter can be used for both continuous (CCM) and discontinuous conduction (DCM) only the continuous conduction mode (CCM) is preferred for the analysis for best understanding of the operation.

3.2 CCM operation

Mode 1: During this time interval $[t0, t1]$, S1 and S2 are turned on and S3 is turned off. The current flow path is shown in Fig. 3(a). The energy of the low-

voltage side V_L is transferred to the coupled inductor. Meanwhile, the primary and secondary windings of the coupled inductor are in parallel. The energy stored in the capacitor CH is discharged to the load. Thus, the voltages across $L1$ and $L2$ are obtained as

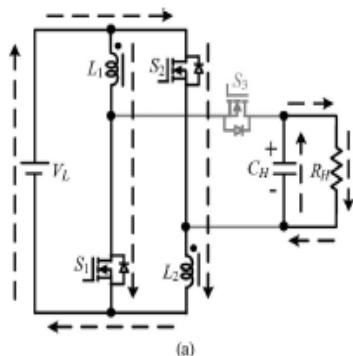

Fig 3 (a) Mode 1

$$v_{L1} = v_{L2} = V_L \quad (5)$$

Substituting (3) & (4) in (5) we get

$$\frac{di_{L1}(t)}{dt} = \frac{di_{L2}(t)}{dt} = \frac{V_L}{(1+k)L}, \quad t_0 \leq t \leq t_1 \quad (6)$$

Mode 2: During this time interval, $S1$ and $S2$ are turned off and $S3$ is turned on. The current flow path is shown in Fig. The low-voltage side V_L and the coupled inductor are in series to transfer their energies to the capacitor CH and the load. Meanwhile, the primary and secondary windings of the coupled inductor are in series. Thus, the following equations are found to be

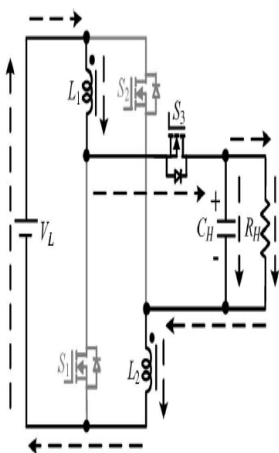

Fig 3 (b) Mode 2

$$i_{L1} = i_{L2} \quad (7)$$

$$u_{L1} + u_{L2} = V_L - V_H \quad (8)$$

By substituting above equations we get

$$\frac{di_{L1}(t)}{dt} = \frac{di_{L2}(t)}{dt} = \frac{V_L - V_H}{2(1+k)L}, \quad t_1 \leq t \leq t_2 \quad (9)$$

By using the state-space averaging method, the following equation is derived from

$$\frac{DV_L}{(1+k)L} + \frac{(1-D)(V_L - V_H)}{2(1+k)L} = 0 \quad (10)$$

By simplifying we get

$$G_{CCM(step-up)} = \frac{V_H}{V_L} = \frac{1+D}{1-D} \quad (11)$$

IV. Matlab Model of Coupled Inductor Dc Converter for PV System

The proposed system was developed on Matlab/simulink in a lucid fashion and in the simple way. The model was simulated only for two inputs and can be further added depending on the requirement. The converters use two coupled inductances of same value. Typically we took a Mutual inductance block and is modeled for two windings only. The temperature of the PV panel is assumed to be 25 K and irradiance constant is assumed to be maintained at 1000. The devices were switched at high frequency. It has to be noted that $S1$ & $S2$ -ON, $S3$ -OFF and vice versa.

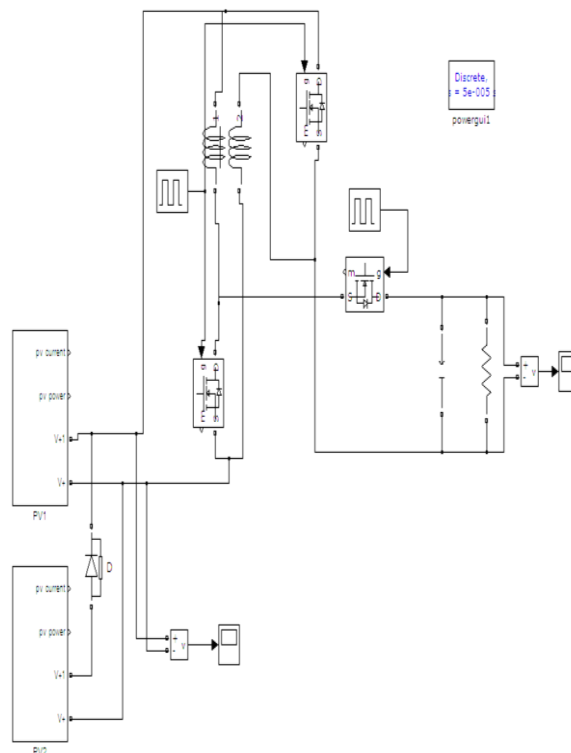

Fig 4 Matlab model of the proposed converter with PV system

Table 4.1 Tabular forum of the parameters

Self inductance L_1	15.5 μ H
Self inductance L_2	15.5 μ H
Capacitance	330 μ F
Load	8.82 Ω
Switching frequency	50 K Hz
Temperature	25
Irradiance	1000

V. Simulation results

The performance of the proposed converter was verified using mat lab/simulink. Some experimental results in step-up are shown in Fig 5, shows the waveforms of the total input current iL and the coupled inductor currents $iL1$ and $iL2$ in step-up mode. It can be observed that $iL1$ is equal to $iL2$.

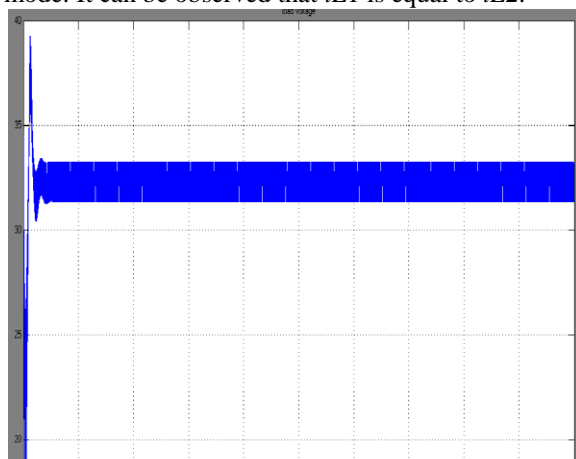

Fig 5(a) Combined Input to the dc converter from pv panels. $V_{in} = 32$ V

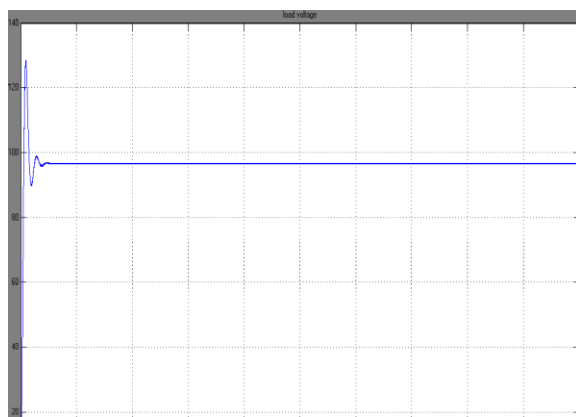

Fig 5(b) Output voltage from the dc converter $V_{OUT} = 96.7V$

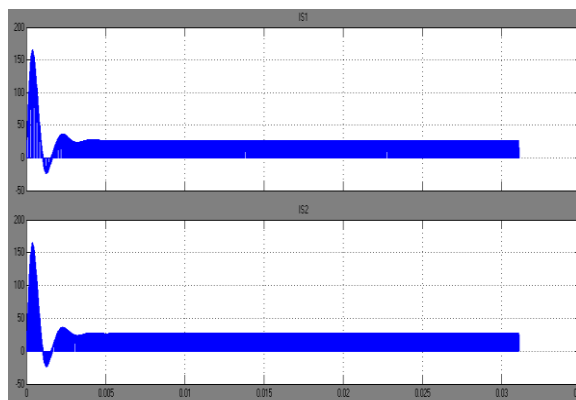

Fig 5(c) Equal Current through switching devices S1 & S2

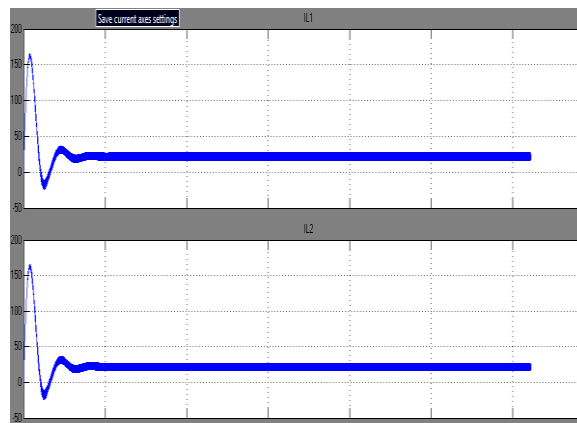

Fig 5 (d) Equal currents through coupling inductors (L_1 & L_2)

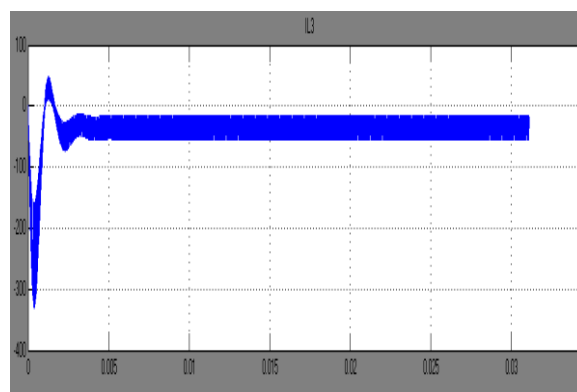

Fig 5(e). Total input current

VI. Conclusion

The proposed dc converter is simple in construction and has more efficiency than the conventional dc-dc converter. This can be used in battery operated vehicles, and solar powered uninterrupted power supplies and can have significant use in renewable energy sources where there is a need of efficient dc conversion.

References

- [1]. Novel high step up dc to dc converter with coupled inductor and switched capacitor for a sustainable energy system by Lung-Sheng Yang and Tsorng-Juu Liang, -IEEE TRANSACTIONS ON INDUSTRIAL ELECTRONICS, VOL. 59, NO. 1, JANUARY 2012
- [2]. Simulation of Closed Loop Controlled Boost Converter for Solar Installation by Athimulam Kalirasu, Subharensu Sekar Dash-SERBIAN JOURNAL OF ELECTRICAL ENGINEERING Vol. 7, No. 1, May 2010, 121-130
- [3]. Simulation of Grid-Connected Photovoltaic System by Jingzhe Song

- [4]. *Design and Simulation by Photovoltaic System with Tapped Topology* by - Juan C. Yris, Hugo Calleja G, Leobardo H. Gonzalez, José A. Olmos -International Journal of Modern Engineering Research (IJMER) Vol.3, Issue.2, March-April. 2013 pp-1238-1244.
- [5]. *A New High Efficient Bi-Directional Dc/Dc Converter In The Dual Voltage System*-Su-Won Lee†, Seong-Ryong Lee* and Chil-Hwan Jeon*-Journal of Electrical Engineering & Technology, Vol. 1, No. 3, pp. 343~350, 2006
- [6]. *High Voltage Gain Boost Converter for Micro source Power Conversion system* by K. Radhalakshmi1, R. Dhanasekaran2-ACEEE Int. J. on Electrical and Power Engineering, Vol. 4, No. 1, Feb 20137. M. B. Camara, H. Gualous, F. Gustin, A. Berthon, and B. Dakyo, "DC/DC converter design for supercapacitor and battery power management in hybrid vehicle applications—Polynomial control strategy," *IEEE Trans. Ind. Electron.*, vol. 57, no. 2, pp. 587–597, Feb. 2010.
- [7]. L. S. Yang, T. J. Liang, and J. F. Chen, "Transformerless dc–dc converters with high step-up voltage gain," *IEEE Trans. Ind. Electron.*, vol. 56, no. 8, pp. 3144–3152, Aug. 2009.
- [8]. R. J. Wai and R. Y. Duan, "High-efficiency bidirectional converter for power sources with great voltage diversity," *IEEE Trans. Power Electron.*, vol. 22, no. 5, pp. 1986–1996, Sep. 2007.
- [9] G. Ma, W. Qu, G. Yu, Y. Liu, N. Liang, and W. Li, "A zero-voltage switching bidirectional dc–dc converter with state analysis and soft switching- oriented design consideration," *IEEE Trans. Ind. Electron.*, vol. 56, no. 6, pp. 2174–2184, Jun. 2009.



G.Shinyvikram was born in year 1985.He received B.Tech and M.Tech during the years 2007 &2009 respectively both in the field of Electrical Engineering.Presently he is working as Assistant Professor & HOD in Swarnandhra Institute Of Engineering & Technology (SIET) ,Seetharampuram-AndhraPradesh.His area of interests includes control strategies in DC converters, power quality issues, stability analysis of power systems etc.,